

Product data sheet

Power connectors



| | |
|---------------------|---|
| Product description | M23 Male coupling connector, Contacts: 19, 6.0-10.0 mm, unshielded, solder, IP67 |
| Area | M23 series 623 |
| Part no. | 99 4639 00 19 |

Illustration



Scale drawing

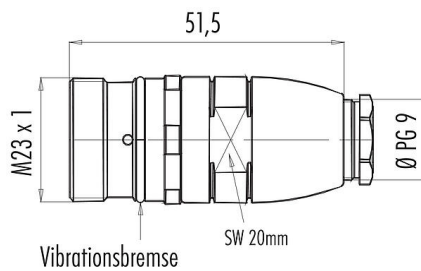

Contact arrangement (Plug-in side)

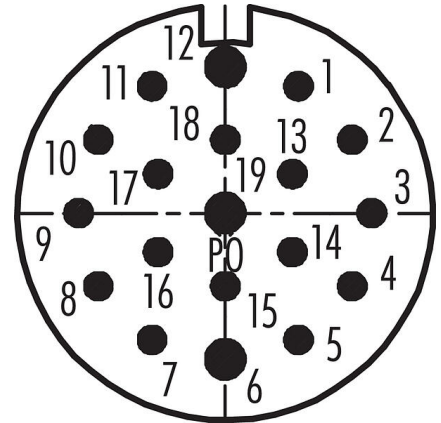

You can find the assembly instructions on the next page.

Technical data

General features

| | |
|---------------------------|---|
| Part no. | 99 4639 00 19 |
| Connector design | Male coupling connector |
| Version | Connector pin straight |
| Connector locking system | screw |
| Termination | solder |
| Degree of protection | IP67 |
| Arrangement of contacts | clockwise |
| Cross-sectional area | 16x1.00 / 3x1.50 mm ² / 16 x AWG 18 / x AWG 16 |
| Cable outlet | 6.0-10.0 mm |
| Temperature range from/to | -25 °C / 125 °C |
| Mechanical operation | > 50 Mating cycles |
| Weight (g) | 85.62 |
| Customs tariff number | 85369010 |

Electrical parameters

| | |
|---------------------------|----------------------|
| Rated voltage | 48 V |
| Rated impulse voltage | 1500 V |
| Rated current (40 °C) | 16x8 A / 3x10 A |
| Insulation resistance | ≥ 10 ¹⁰ Ω |
| Pollution degree | 3 |
| Overvoltage category | II |
| Insulating material group | III |
| EMC compliance | unshielded |

| | |
|---------------------|---|
| Product description | M23 Male coupling connector, Contacts: 19, 6.0-10.0 mm, unshielded, solder, IP67 |
| Area | M23 series 623 |
| Part no. | 99 4639 00 19 |

Material

| | |
|-----------------------|--------------------------------------|
| Contact body material | PET (UL94 V-0) |
| Contact material | CuZn (brass) |
| Contact plating | Au (gold) |
| REACH SVHC | CAS 7439-92-1 (Lead) |
| SCIP number | ba3c4d1d-1a61-4021-8019-7935ad1a3fc2 |

Classifications

| | |
|-------------|-------------|
| eCl@ss 11.1 | 27-44-01-02 |
| ETIM 7.0 | EC002635 |

Assembly instructions

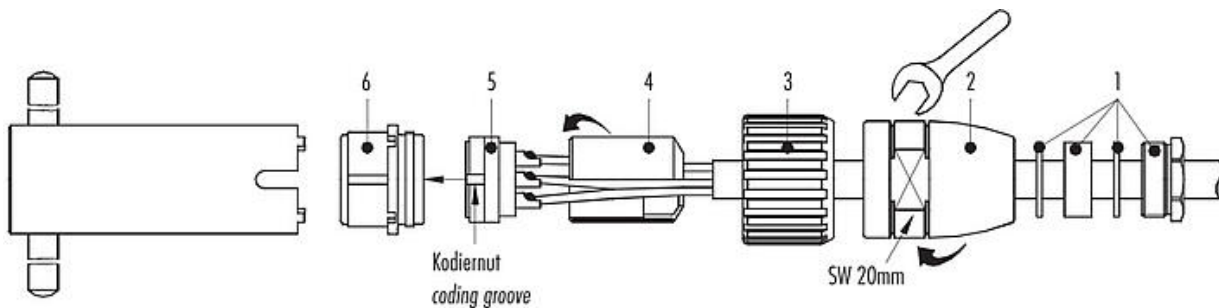

- Push the cable screw connection (1), adapter (2) and coupling nut (3) onto the cable.
- Strip the cable coating by 20 mm.
- Trim foil, filler and inner insulation.
- Strip the single wires by 3.5 mm, twist and tin.
- Solder the single wires to the contacts.
- Insert the distance shell (4).
- Guide the insert (5) and distance shell (4) into the insert ring (6), mind that the desired coding groove of the insert (6) is pushed into the coding bar.

- Screw the adapter (2) as tight as possible.
- Screw the cable gland (1) as tight as possible.

Please note: torque for clamping screw for contact insert (5) with screw contacts:

- max. 0.1 Nm for screw contacts with mating dia. 1 mm
- max. 0.2 Nm for screw contacts with mating dia. 2 mm

| | |
|---------------------|---|
| Product description | M23 Male coupling connector, Contacts: 19, 6.0-10.0 mm, unshielded, solder, IP67 |
| Area | M23 series 623 |
| Part no. | 99 4639 00 19 |

Security notices

The connector must not be plugged or unplugged under load. Non-observance and improper use can result in personal injury.

The connectors have been developed for applications in plant engineering, control and electrical equipment construction. The user is responsible for checking whether the connectors can also be used in other areas of application.

Connectors which are used in circuits with voltages dangerous to the touch may only be installed and used by, or under the supervision of, persons with electrical engineering training, taking into account the applicable regulations and standards.

Plug connectors with enclosure protection IP67 and IP68 are not suitable for use under water. When used outdoors, the plug connectors must be protected separately against corrosion. For further information on the IP protection classes, please refer to the "Technical Information" download centre.

To lock the cable connector with the device connector, the threaded ring is tightened "hand-tight" (approx. 50 cNm).